

VERMEIREN

708D

INSTRUCTION MANUAL





Instructions to the specialist dealer

This instruction manual is part and parcel of the product and must accompany every product sold.

Version: A, 2015-03

All rights reserved, including translation.

No part of this manual may be reproduced in any form whatsoever (print, photocopy, microfilm or any other process) without written permission of the publisher, or processed, duplicated or distributed by using electronic systems.

© N.V. Vermeiren N.V. 2015

Contents

Preface	2
1 Product description	3
1.1 Intended Use.....	3
1.2 Technical specifications	4
1.3 Components.....	5
1.4 Accessories.....	5
1.5 Location identification plate.....	5
1.6 Explanation of symbols.....	6
1.7 Safety rules.....	6
2 Use	6
2.1 Carrying the wheelchair	7
2.2 Mounting the rear wheels (if quick release axle is available).....	7
2.3 Unfolding the wheelchair	7
2.4 Mounting or removing of the footrests	7
2.5 Operating the brakes.....	8
2.6 Mounting or removing of armrests.....	8
2.7 Transfer in and out the wheelchair	9
2.8 Correct position in the wheelchair	9
2.9 Riding the wheelchair.....	9
2.10 Moving on slopes	10
2.11 Negotiating steps or kerbs	10
2.12 Fold up the wheelchair	11
2.13 Taking off the wheels (if quick release axle is available)	12
2.14 Transport in the car.....	12
2.15 Use of the wheelchair as seat in a motor vehicle	12
3 Installation and adjustment	14
3.1 Tools	14
3.2 Manner of delivery	14
3.3 Anatomical seat (OPTIONAL)	15
3.4 Anatomical backrest (OPTIONAL)	15
3.5 Adjust the brakes.....	15
3.6 Adjusting of the footrests	16
4 Maintenance	16



Preface

First of all we want to thank you for putting your trust in us by selecting one of our wheelchairs.

The Vermeiren wheelchairs are the result of many years of research and experience. During the development, special attention was given to the ease of use and the serviceability of the wheelchair.

The expected lifetime of your wheelchair is strongly influenced by the care and maintenance of the wheelchair.

This manual will help you get acquainted with the operation of your wheelchair.

Following the user instructions and the maintenance instructions are an essential part of the warranty.

This manual reflects the latest product developments. Vermeiren has the right to introduce changes without the obligation to adapt or replace previously delivered models.

For any further questions, please consult your specialist dealer.

1 Product description

1.1 *Intended Use*

The wheelchair is intended for people with walking difficulties or no walking abilities.

The wheelchair is designed to transport 1 person.

The wheelchair is suited for indoor and outdoor use.

The user can propel the wheelchair by himself or have the wheelchair pushed by an attendant.

The different types of fittings and accessories, and the modular construction allow full use by persons disabled by:

- paralysis
- loss of limbs (leg amputation)
- limb defects or deformations
- stiff or damaged joints
- heart insufficiencies and poor blood circulation
- balance disturbances
- cachexia (decrease in muscle)
- and also for aged persons.

When providing for individual requirements:

- body size and weight (max. 120kg)
- physical and psychological condition
- residential circumstances
- environment

should be taken into consideration.

Your wheelchair should only be used on surfaces where all four wheels are touching the ground and where there is sufficient contact to propel the wheels equally.

You should practice for use on uneven surfaces (cobblestones, etc.), slopes, curves and to get past obstacles (kerbs, etc.).

The wheelchair should not be used as a ladder, nor is it a transport for heavy or hot objects.

When used on mats, carpeted floors or loose floor coverings, the floor covering can get damaged.

Use only Vermeiren approved accessories.

The manufacturer is not liable for damage caused by the lack of or improper service or as a result of not following instructions from this manual.

Compliance with the user and maintenance instructions are an essential part of the guarantee conditions.

1.2 Technical specifications

Technical terms below are valid for the wheelchair in standard settings.

If other footrests / armrests or other accessories are used, the tabulated values will change.

Make	Vermeiren					
Address	Vermeirenplein 1/15, B-2920 Kalmthout					
Type	Manual wheelchair					
Model	708D					
Maximum occupant mass	120 kg					
Description	Dimensions					
Effective seat width	390 mm	420 mm	440 mm	460 mm	480 mm	500 mm
Overall width (depends on the seat width)	560 mm	590 mm	610 mm	630 mm	650 mm	670 mm
Description	Dimensions Min.			Dimensions Max.		
Overall length with legrest	1109 mm					
Folded length without legrest	805 mm					
Folded width	280 mm					
Folded height	910 mm					
Total mass	± 18 kg					
Mass of heaviest part	10,10 kg					
Masses of parts that can be dismantled or removed	Footrests: 1,90 kg; Armrests: 1,85 kg;			Rear wheels: 4,15 kg		
Static stability downhill	15°					
Static stability uphill	15°					
Static stability sideways	15°					
Obstacle climbing	60 mm					
Seat plane angle	4°					
Effective seat depth	430 mm					
Seat surface height at front edge	490 mm					
Backrest angle	4°					
Backrest height	420 mm					
Distance between footrest and seat	383 mm		458 mm			
Angle between seat and footplate	10°					
Angle between seat and leg footrest	65°					
Angle between leg footrest and footplate	105°					
Distance between armrest and seat	225 mm					
Front location of armrest structure	305 mm					
Handrim diameter	535 mm					
Horizontal location of axle (deflection)	21 mm					
Minimum turning radius	1619 mm					
Diameter PU Rear wheels	24"					
Tyre pressure, rear (driving) wheels	Max. 3.5 bar					
Diameter PU steering wheels	200 mm					
Tyre pressure, steering wheels	Max. 2.5 bar					
Storage and use temperature	+ 5 °C		+ 41 °C			
Storage and use humidity	30%		70%			

We reserve the right to introduce technical changes. Measurement tolerance ± 15 mm / 1,5 kg / °

Table 1: Technical specifications 708D

The wheelchair complies to the requirements set up in:

ISO 7176-8: Requirements and test methods for static, impact and fatigue strengths.

EN 1021-1: Assessment of the ignitability of upholstered furniture - Ignition source smouldering cigarette

EN 1021-2: Assessment of the ignitability of upholstered furniture - Ignition source match flame equivalent

ISO 7176-19: Wheeled mobility devices for use as seats in motor vehicles.

1.3 Components

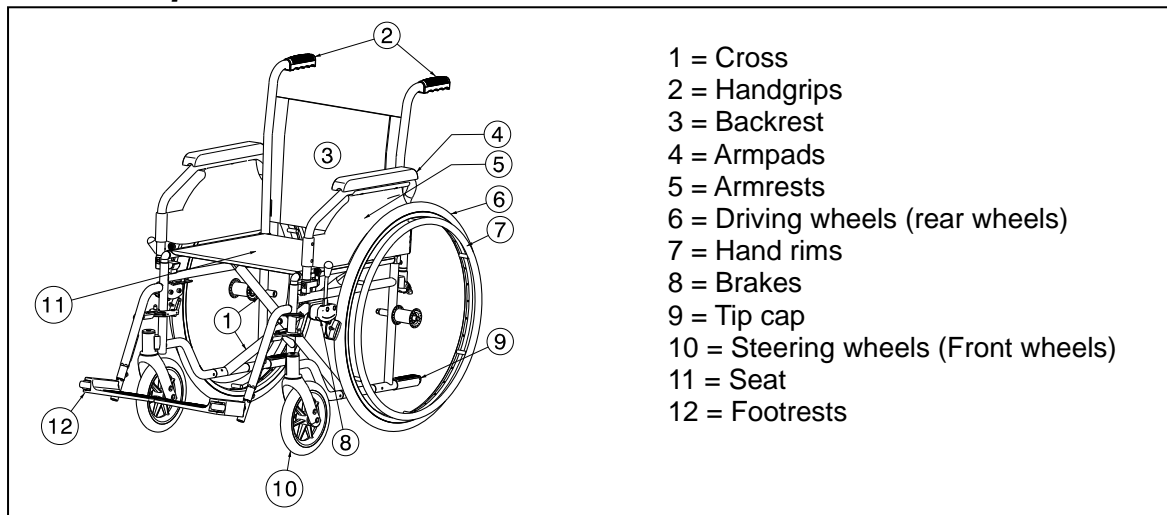

1.4 Accessories



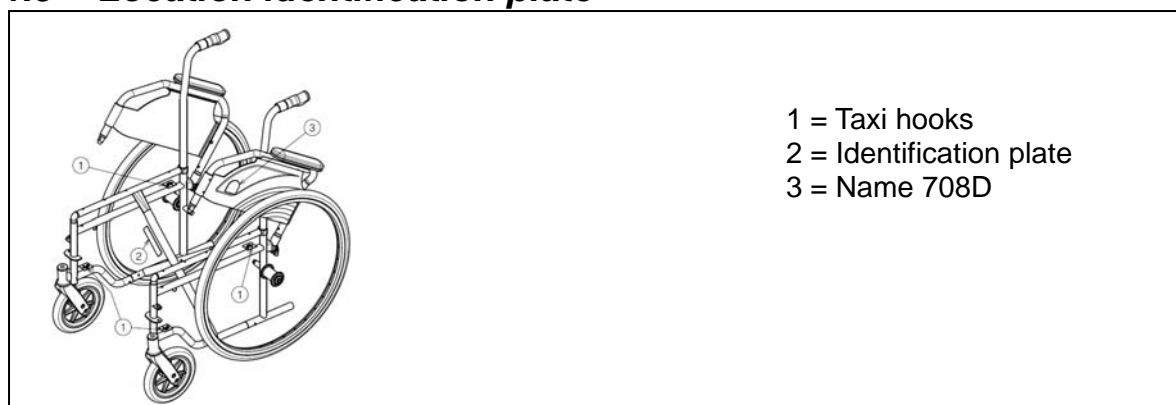

The following accessories are available for the 708D:

- Armrests (B02, B03, B05, B66)
- Footrests / Legrests (B06, B07, B08, BZ7, BZ8, BZ9, BZ10, BK7, BL7, BA6, BK6)
- Table (B12)
- Crutch holder (B31)
- Backrest (L14, L24, L44)
- Anterior pelvic belt (B58) for mounting over the backrest tube
- Anti-tipping device (B78) for mounting on the bottom back frame
- Drum brakes for the attendant (B74) for mounting on the push handgrips
- Transit wheelchair (T30)
- Moving the axle back (AMP)
- Quick release (B80)
- Lowering seat height to 470 mm (S)

1.5 Location identification plate



1.6 Explanation of symbols

-  Maximum mass
-  Indoor and outdoor use
-  Maximum safe slope
-  CE conformity
-  Type designation

1.7 Safety rules

- ⚠ To prevent injury and/or damage to your wheelchair, make sure that no objects and/or body parts are caught in the spokes of the driving wheels.
- ⚠ The parking brakes should be applied before getting into and out of the wheelchair.
- ⚠ When getting into and out of the wheelchair, do not stand on the footplates. These should be folded up beforehand, or the footrests should be swung completely outwards out of the way.
- ⚠ Investigate the effects of shifting the centre of gravity on the behavior of the wheelchair, for example on up or down gradients, on laterally sloping ground, or when overcoming obstacles. Obtain support from an attendant.
- ⚠ If you want to pick up something (lying in front of, on the side, or to the rear of the wheelchair), you should not lean too far out to avoid tipping over.
- ⚠ When moving through doors, arches, etc. ensure that there is enough room at the sides so that you do not get your hands or arms caught or crushed and that there is no damage to the wheelchair.
- ⚠ Only use your wheelchair according to regulations. For example, avoid uncontrolled rolling against obstacles (steps, kerbs, doorframes, etc) or dropping down from ledges. The manufacturer cannot assume liability for damage caused by overloading, collision or other improper use.
- ⚠ Stairs may only be negotiated when aided by another person. If furnishings like drive-on, ramps or lifts are available, use them.
- ⚠ When moving on the public highway, you are subject to the rules of the road.
- ⚠ When driving your wheelchair, you should not be under the influence of alcohol or medicine as in the case of driving other vehicles. This also applies to indoor driving.
- ⚠ When travelling outdoors, adapt your driving to weather and traffic conditions.
- ⚠ When transporting the wheelchair, never pick it up by grasping movable parts (armrests, footrests, etc.)
- ⚠ To be better visible when driving in the dark, wear the brightest possible clothing or clothes with reflectors, and check that the reflectors mounted on the sides and rear of the wheelchair are clearly visible.
- ⚠ Be careful when using possible causes of fire such as cigarettes since they may set the seat and back covers alight.
- ⚠ Never exceed the maximum load of 120 kg.

2 Use

This chapter describes the everyday use. **These instructions are for the user and the specialist dealer.**

The wheelchair is delivered fully assembled by your specialist dealer. The instructions intended for the specialist dealer on how to set up the wheelchair are given in § 3.

2.1 Carrying the wheelchair

The best way to carry the wheelchair is to make use of the wheels and roll the wheelchair. If this is not possible (e.g. when the rear wheels are taken off for transportation in a car), firmly grasp the frame on the front and the grips. Do not use the foot- or armrests or the wheels to grasp the wheelchair.

2.2 Mounting the rear wheels (if quick release axle is available)

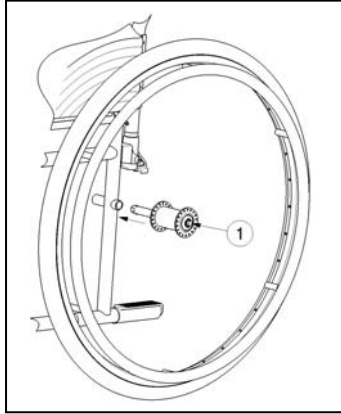

1. Take the rear wheel and push on button ①.
2. Keep the button pushed in and mount the rear wheels axle till it stops.
3. Release the button.
4. Check that the wheel is secured.

2.3 Unfolding the wheelchair

⚠ CAUTION: Risk of clamping – Keep fingers away from moving parts of the wheelchair.

1. Position yourself behind the wheelchair.
2. Use the handgrips to open the wheelchair as much as possible.
3. Position yourself at the front of the wheelchair.
4. Push both seating tubes down till they are fixed in their position.

2.4 Mounting or removing of the footrests

⚠ WARNING: Risk of injury – Check that the footrests are securely locked in place before use.

⚠ CAUTION: Risk of clamping – Keep objects and people away from the footrests swing range.

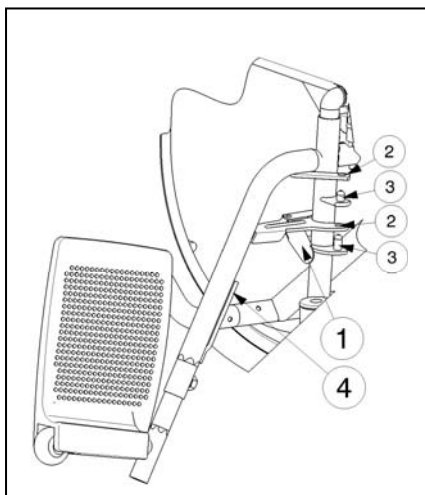

The mounting of the footrests is done as follows:

1. Hold the footrest sideways at the outside of the wheelchairs frame.
2. Mount the holes ② of the footrest on the pins ③ located on the frame.
3. Turn the footrest inwards till it clicks in position. If this lock is a little stiff, press the lever gently back.
4. Turn the footplate downwards.
5. Replace the calf strap in the hooks ④.

To take off the footrests:

1. Remove the calf strap by unhooking it on both sides.
2. Pull back the lever ① near the footrest attachment.
3. Turn the footrest to the outside of the wheelchair.
4. Lift the holes ② of the footrest out of the pins located on the frame ③.

2.5 Operating the brakes

- ⚠ **WARNING:** The brakes are not used to slow down the wheelchair during movements – Use the brake only to prevent the wheelchair from unintended movements.
- ⚠ **WARNING:** Good operation of the brakes is influenced by wear and contamination of the tires (water, oil, mud, ...) – Check the condition of the tires before each use.
- ⚠ **WARNING:** The brakes are adjustable and can wear – Check the operation of the brakes before each use.

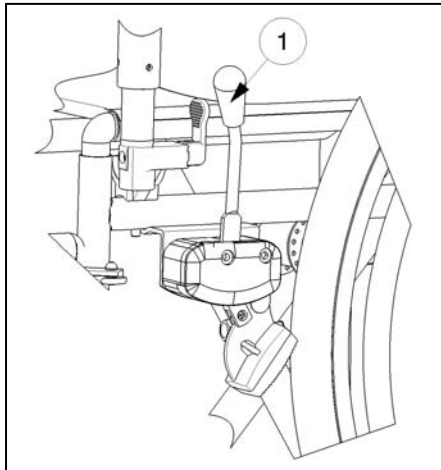

To apply the brakes:

1. Push the brake levers ① forward till you feel a distinctive click.

⚠ **CAUTION:** Risk of unintended movement – Make sure the wheelchair is on a flat horizontal surface before releasing the brakes. Never release both brakes simultaneously.

To release the brakes:

1. Release one brake by pulling the lever ① backwards.
2. Hold the hand-rim of the released wheel with your hand.
3. Release the second brake by pulling the lever backwards.

2.6 Mounting or removing of armrests

⚠ **CAUTION:** Risk of clamping – Keep fingers, buckles and clothes away from the bottom side of the armrest.

The armrests of the wheelchair can be mounted by following instructions.

1. Mount the rear tube of the arm rest in tube hood ① (Fig A).
2. Make sure the arm support is mounted very well.
3. Fold the armrest forward.
4. Pull the lever ② on tube hood ③ upwards (Fig B).
5. Click the front tube of the armrest ④ in tube hood ③ (Fig B).

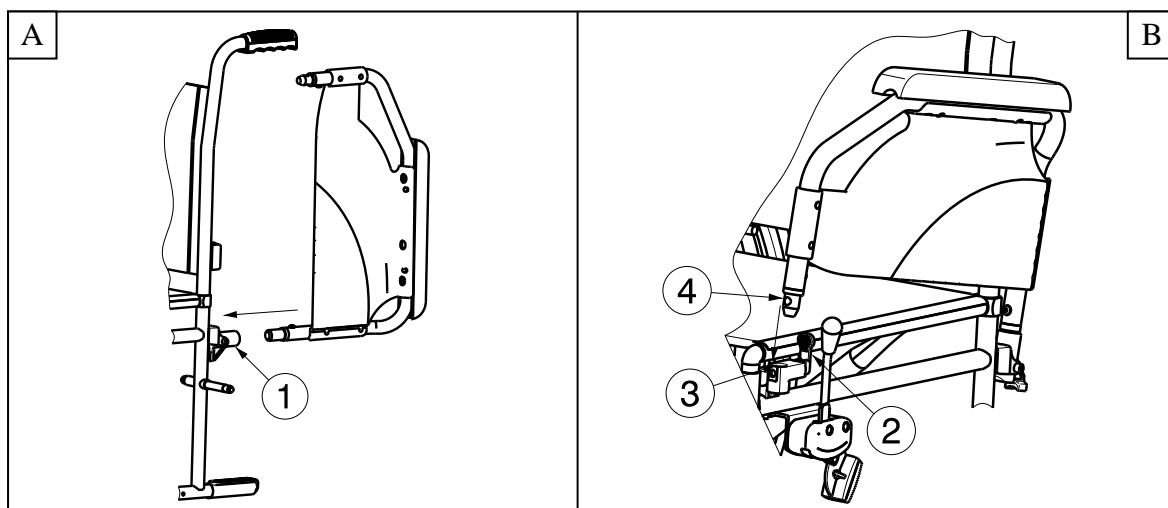

To open and remove the armrest:

1. Pull lever ② and pull the front of the arm rest ① upwards (Fig C).
2. Fold the armrest backwards.
3. To remove the armrest, pull the rear of the armrest from tube hood ③ (Fig D).

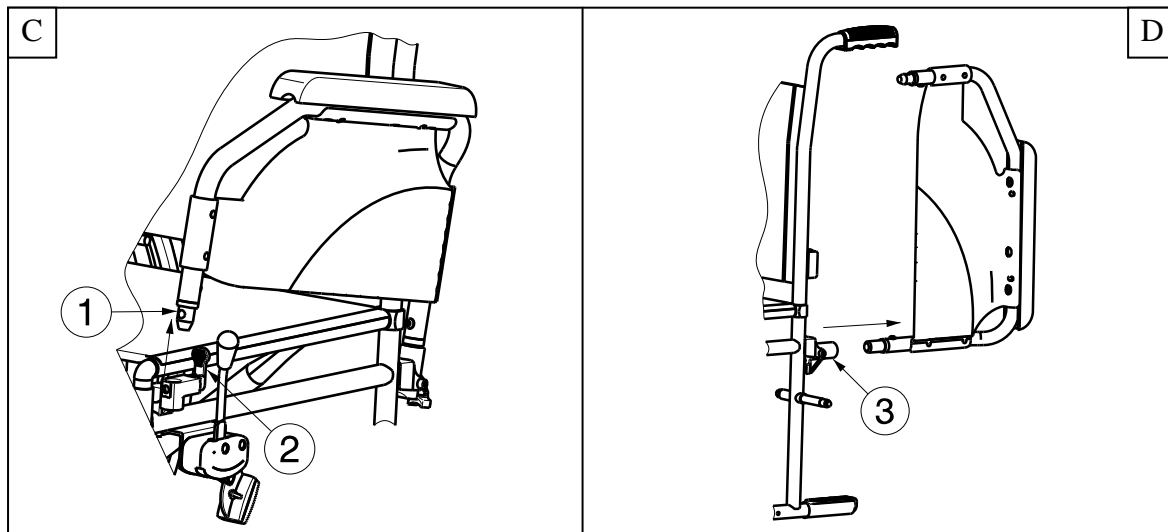

2.7 Transfer in and out the wheelchair

- ⚠ **CAUTION:** In case you cannot perform the transfer in a safe manner, ask someone to assist you.
- ⚠ **CAUTION:** Risk of tipping over of the wheelchair – Do not stand on the footplates.

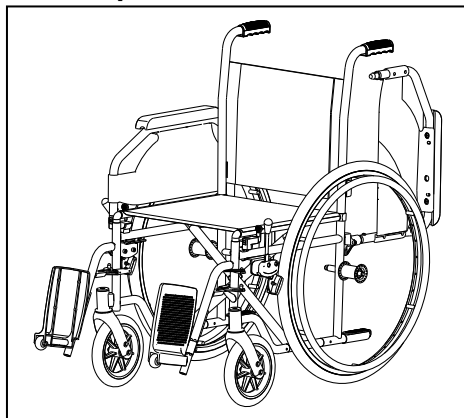

1. Position the wheelchair as close as possible to the chair, couch or bed to/from you wish to transfer.
2. Check both brakes from the wheelchair are in the on position.
3. Fold the footplates upwards to prevent standing on them.
4. If the transfer is on the side of the wheelchair, fold the armrest on that side upwards. (see § 2.6)
5. Transfer to/from the wheelchair.

2.8 Correct position in the wheelchair

Some recommendations for a comfortable use of the wheelchair:

- Position your backside as close as possible to the backrest.
- Make sure your upper legs are horizontal – If needed adjust the length of the footrests (see § 3.6.1).

2.9 Riding the wheelchair

- ⚠ **WARNING:** Risk of clamping – Prevent your fingers from being caught by the wheels spokes.
- ⚠ **WARNING:** Risk of clamping – Be careful passing through restricted passages (e.g. doors).
- ⚠ **WARNING:** Risk of burns – Be careful when driving in hot or cold environments (sunshine, extreme cold, saunas, etc.) for a sufficient amount of time and when touching - Surfaces can assume the environment temperatures.

1. Release the brakes.
2. Take both hand rims at their highest position.
3. Lean forward and push the hand rims forward until straight arms.
4. Swing your arms loosely back to the hand rims topside and repeat the movement.

2.10 Moving on slopes

- ⚠ **WARNING: Control your speed – Moving on slopes as slow as possible.**
- ⚠ **WARNING: Consider the capacities of your attendant – If your attendant does not have enough force to control the wheelchair, put on the brakes.**
- ⚠ **WARNING: Risk of tipping over – Lean forward to move your centre of gravity forward. To improve a better stability.**



1. If available on the wheelchair, wear the safety belt.
2. Do not attempt moving on too high slopes. The maximum slope angles (upwards and downwards) are mentioned in table 1.
3. Ask an attendant to help you moving on the slope.
4. Lean forward to move your centre of gravity forward.

2.11 Negotiating steps or kerbs

2.11.1 Getting down steps or kerbs

Riding down low kerbs can be done moving forwards. Make sure that the foot rests do not touch the ground.



A practiced user can negotiate small steps or kerbs by himself:

- ⚠ **WARNING: Risk of tipping over – If you do not have enough experience with your wheelchair, ask assistance of an attendant.**
1. Bring balance on the rear wheels to reduce the pressure on the front wheels.
 2. Negotiate the kerbs.

Higher kerbs can be taken forward with an attendant:

1. Ask the attendant to tip the wheelchair slightly backwards.
2. Get past the kerbs while moving on the rear wheels.
3. Put the wheelchair back on the four wheels.



An experienced user can negotiate higher kerbs by himself. This is best done backwards.

1. Turn the wheelchair to have the rear wheels facing the kerb.
2. Lean forward to move your centre of gravity forward.
3. Move the wheelchair close to the kerbs.
4. Use the hand rim to roll-off wheelchair from the kerb in a controlled manner.

2.11.2 Moving up steps or kerbs

Moving up steps or kerbs with attendant as follows:



1. Prevent the footplates from touching the kerb.
2. Ask the attendant to tip the wheelchair backwards, just enough to move the front wheels over the kerb.
3. Lean backwards to move your centre of gravity above the rear wheel.
4. Place the front wheels on the kerb.
5. Roll rear wheels of the wheelchair over the kerb.

Higher kerbs are negotiated backwards:

1. Turn the wheelchair to have the rear wheels facing the kerb.
2. Lean backwards and move your centre of gravity above the rear wheels.
3. Ask the attendant to pull the wheelchair on the kerb.
4. Take back the normal position in the wheelchair.

An experienced user can negotiate kerbs by himself:

⚠ WARNING: Risk of tipping over – If you have not enough experience to control the wheelchair, get help from an attendant.



1. Drive until the kerbs.
2. Ensure that the footplates do not touch the kerbs.
3. Lean backwards so you are balancing on the rear wheels.



4. Role the frontwheels balancing over the kerbs.
5. Bend forward for more stability.
6. Role the rear wheels over the kerbs.

2.11.3 Taking of stairs

Taking of stairs while you staying in the wheelchair shall be according following rules:

⚠ WARNING: Risk of tipping over – Taking of stairs shall always with 2 attendants.

1. Remove the footrests.
2. One attendant tip the wheelchair slightly backwards.
3. The second attendant take the front of the frame.
4. Stay calm, avoid sudden movements and keep your arms inside the wheelchair.
5. Take the steps on the rear wheels of the wheelchair.
6. Mounting the footrests back after taking the stair.

2.12 Fold up the wheelchair

⚠ CAUTION: Chance of pinching – Do not place fingers between the components of the wheelchair.

1. Fold or remove the footplates (see § 2.4).
2. Take the seat on the front side and backside and pull it up.

2.13 Taking off the wheels (if quick release axle is available)

To facilitate the transport off the wheelchair the rear wheels can be taken off:

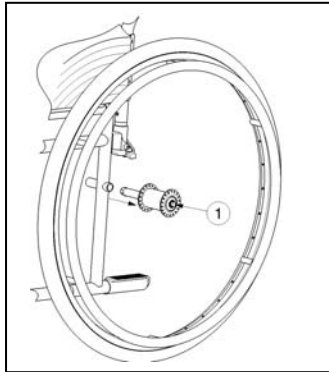

1. Make sure the brakes standing in the off position.
2. Take the wheelchair to the side frame where you want to remove the wheel.
3. Press the button ① in the center of the wheel hub.
4. Pull the wheel away from the frame.

2.14 Transport in the car

⚠ WARNING: Risk of injury – See that the wheelchair is attached properly. So you can avoid injury from the passengers during collision or sudden braking.

⚠ WARNING: Risk of injury – Use for attaching the wheelchair and passenger NEVER the same seatbelt.

1. Remove footrests and accessories.
2. Store footrests and accessories safely.
3. If possible, fold the wheelchair and remove the wheels.
4. Place the wheelchair in the luggage place.
5. If the wheelchair and the passenger compartment is NOT separated, attach the frame of the wheelchair securely to the vehicle. You can use the available safety belts in the vehicle.

2.15 Use of the wheelchair as seat in a motor vehicle

⚠ WARNING: The wheelchair has passed the crash of ISO 7176-19: 2008 and, as such, has been designed and tested for use only as forward-facing seat in a motor vehicle.

⚠ WARNING: The wheelchair's pelvic belt alone is not suited as an occupant restraint belt.

The wheelchair is tested using the four-point strap-tie system and a 3-point occupant-restraint system.

Whenever feasible, use the seat of the vehicle and store the wheelchair in the cargo area.

Steps to secure the wheelchair in a motor vehicle:

1. Check that the vehicle is equipped with a suitable wheelchair tie down and occupant-restraint system, conform ISO 10542.
2. Check that the components of the wheelchair tie down and occupant restraint system are not frayed, contaminated, damaged or broken.
3. If equipped with an adjustable seat and/or back tilt, make sure that the wheelchair user is sitting as upright as possible. If the user's condition prevents this, a risk assessment should be done to evaluate the user's safety during transit.
4. Remove all mounted accessories such as trays and respiratory equipment, and secure them in a safe place.
5. Position the wheelchair facing forward in the travelling direction, centrally between the tie-down rails mounted in the floor of the vehicle.
6. Make sure that the indicated zones around the wheelchair user are clear from rigid vehicle parts.

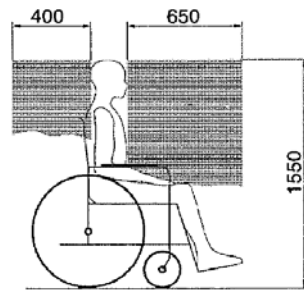

figure 1

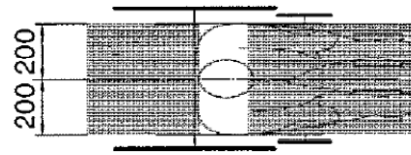

figure 2

7. Mount the front securement straps according to the instructions of the strap-system manufacturer at the indicated place. (figure 3)
This place is marked on the wheelchair with a symbol. (figure 4)
8. Roll back the wheelchair until the front straps are tight.
9. Apply the wheelchair brake.
10. Mount the back securement straps according to the instructions of the strap-system manufacturer at the indicated place. (figure 3)
11. This place is marked on the wheelchair with a symbol. (figure 4)

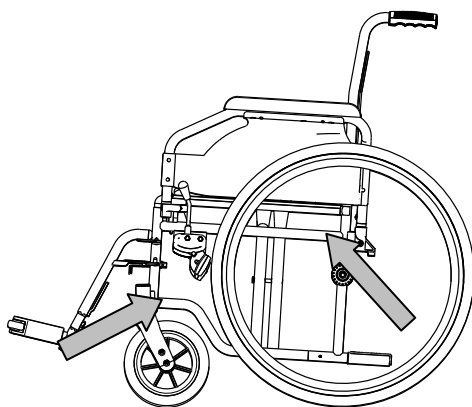

figure 3



figure 4

Steps to secure the wheelchair user:

1. Remove both armrests.
2. If present, attach the wheelchair's pelvic belt.
3. Attach the occupant restraint belts according to the instructions of the strap-system manufacturer.
4. Wear the pelvic belt low across the front of the pelvis, so that the angle of the pelvic belt is within the preferred zone of 30° to 75° to the horizontal, similar to that shown below.

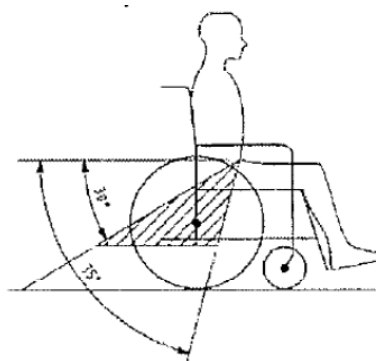

5. A steeper (greater) angle within the preferred zone is desirable.
6. Adjust the belt tightly according to the instructions of the strap-system manufacturer, consistent with the user's comfort.
7. Ensure that the restraint belt connects in a straight line to the anchor point in the vehicle and that no bends in the belt are visible, for instance at the axle of the rear wheel.
8. Install the armrests, if desired. Make sure that belts are not twisted or held away from the body by wheelchair components such as armrests or wheels.



3 Installation and adjustment

The instructions in this chapter are for the specialist dealer.

The Vermeiren wheelchairs 708D has been designed entirely for your comfort.

To find a service facility or specialist dealer near you, contact the nearest Vermeiren facility. A list of Vermeiren facilities can be found on the last page.

- ⚠ **WARNING:** Risk of unsafe settings - Use only the settings described in this manual.
- ⚠ **WARNING:** Variation of allowed adjustments can still change the stability of your wheelchair (tilt back or sideways).

3.1 Tools

To set up the wheelchair the following tools are needed.

- Wrench set n° 10 to n° 19
- Allen key set n° 4 to n° 5
- Screwdriver Phillips head

3.2 Manner of delivery

The Vermeiren 708D shall be delivered with:

- 1 frame with armrests, rear and front wheels
- 1 pair footrests
- Backrest and seat cushions
- Tools
- Manual
- Accessories (optional)
- Pump (with pneumatic tyres only)

Before use check if everything is included and that no products are damaged (example by transport, ...).

3.3 Anatomical seat (OPTIONAL)

⚠ WARNING: Risk of injury – Check that the seat is secure before use.

⚠ WARNING: Risk of injury – Avoid getting your fingers caught during the assembly process.

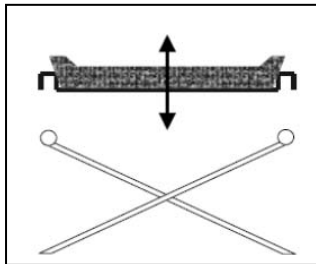

If you have opted for an anatomical padded seat, place it on the tubular cross-hinge so that the seat's supports engage equally with the cross-hinge. In the wooden base you will find slots that are placed in the hinge's cross-pieces. To fold up the wheelchair, remove the seat by pulling it upwards.

3.4 Anatomical backrest (OPTIONAL)

⚠ WARNING: Risk of injury – Check that the backrest is secure before use.

⚠ WARNING: Risk of injury – Avoid getting your fingers caught during the assembly process.

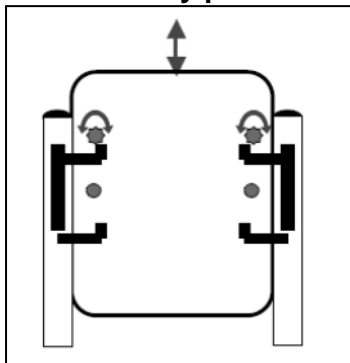

To use the anatomical backrest, proceed as follows:

1. Unscrew the flexible backrest.
2. Loosely screw on the brackets for the backrest.
3. Insert the backrest into the brackets from above.
4. Tighten the screws holding the brackets for the backrest.
5. Insert and tighten the safety screws for the backrest.
6. Add the armrests.

3.5 Adjust the brakes

⚠ WARNING: Risk of injury – Brakes may only be adjusted by your specialist dealer.

Adjust the brakes according following rules:

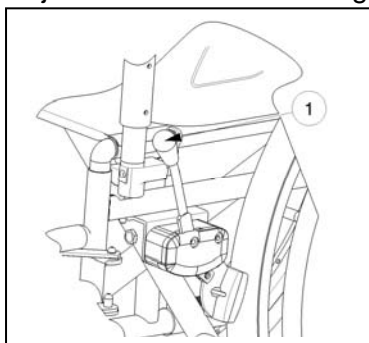

1. Install the wheels according § 2.2.
2. Disconnect the brakes by pulling lever ① backwards.

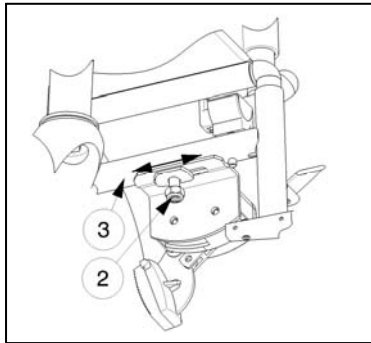

3. Loosen the selflocking nut ② so the brake mechanism can slide over the frame tube ③.
4. Pull the brake mechanism over the tube ③ to the desired position. (the adjustments range shall be possible between the groove on the brake montage plate)
5. Retighten the selflocking nut ②.
6. Check working of the brakes.
7. If necessary repeat the above steps until the brakes are adjusted well.

3.6 Adjusting of the footrests

3.6.1 Length of the footrests

⚠ CAUTION: Risk of damage – Avoid that the footplates make any contact with the ground. Keep a minimum distance from 60 mm above the ground.

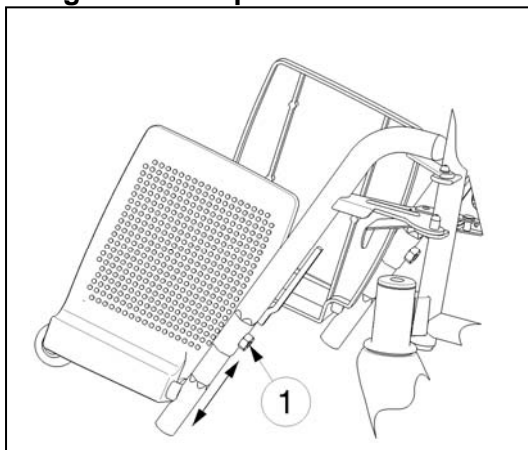

Adjust the length of the footrests as follow:

1. Remove the Allen screw ① on the lower end of the upper part of the footrests.
2. Adjust the length of the footrest to a comfortable length by moving the hexagonal inner tube out or in.
3. Tighten the Allen screw ① properly.

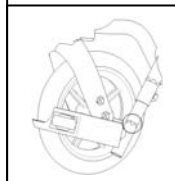

The minimum length is when the footrest tube changes from hexagonal in round.

The maximum length is until the mark in the tube (These mark is a straight line).

4 Maintenance

For the maintenance manual of the wheelchairs refer to the Vermeiren website:
www.vermeiren.com.



SERVICE

The manual wheelchair was serviced:

Dealer's stamp:

Date:

Dealer's stamp:

Date:

Dealer's stamp:

Date:

Dealer's stamp:

Date:

Dealer's stamp:

Date:

Dealer's stamp:

Date:

Dealer's stamp:

Date:

Dealer's stamp:

Date:

Dealer's stamp:

Date:

Dealer's stamp:

Date:

- For service checklists an additional technical information, please see our specialist dealers nearest to you. More information on our website at: www.vermeiren.com.

Belgium

N.V. Vermeiren N.V.

Vermeirenplein 1 / 15
B-2920 Kalmthout
Tel: +32(0)3 620 20 20
Fax: +32(0)3 666 48 94
website: www.vermeiren.be
e-mail: info@vermeiren.be

France

Vermeiren France S.A.

Z. I., 5, Rue d'Ennevelin
F-59710 Avelin
Tel: +33(0)3 28 55 07 98
Fax: +33(0)3 20 90 28 89
website: www.vermeiren.fr
e-mail: info@vermeiren.fr

Italy

Vermeiren Italia

Viale delle Industrie 5
I-20020 Arese MI
Tel: +39 02 99 77 07
Fax: +39 02 93 58 56 17
website: www.reatime.it
e-mail: info@reatime.it

Poland

Vermeiren Polska Sp. z o.o

ul. Łączna 1
PL-55-100 Trzebnica
Tel: +48(0)71 387 42 00
Fax: +48(0)71 387 05 74
website: www.vermeiren.pl
e-mail: info@vermeiren.pl

Czech Republic

Vermeiren ČR S.R.O.

Nadrazni 132
702 00 Ostrava 1
Tel: +420 596 133 923
Fax: +420 596 133 277
website: www.vermeiren.cz
e-mail: info@vermeiren.cz

Germany

Vermeiren Deutschland GmbH

Wahlerstraße 12 a
D-40472 Düsseldorf
Tel: +49(0)211 94 27 90
Fax: +49(0)211 65 36 00
website: www.vermeiren.de
e-mail: info@vermeiren.de

Austria

Vermeiren Austria GmbH

Schärdinger Strasse 4
A-4061 Pasching
Tel: +43(0)732 37 13 66
Fax: +43(0)732 37 13 69
website: www.vermeiren.at
e-mail: info@vermeiren.at

Switzerland

Vermeiren Suisse S.A.

Hühnerhubelstraße 59
CH-3123 Belp
Tel: +41(0)31 818 40 95
Fax: +41(0)31 818 40 98
website: www.vermeiren.ch
e-mail: info@vermeiren.ch

Spain / Portugal

Vermeiren Iberica, S.L.

Carratera de Cartellà, Km 0,5
Sant Gregori Parc Industrial Edifici A
17150 Sant Gregori (Girona)
Tel: +34 972 42 84 33
Fax: +34 972 40 50 54
website: www.vermeiren.es
e-mail: info@vermeiren.es